

Tradition since 1883

Precision – Made in Germany

As a fast growing high-tech company, Schubert & Salzer Control Systems GmbH develops, produces and distributes highly precise control and on/off valves which are applied in the process industry. Whether it is in the production of chemical or pharmaceutical products, food and beverage processing or the production of plastics, steel, paper or glass, as well as in the textile industry – in short, wherever liquid or gaseous flows need to be controlled or shut off, we will be there for you.

We are part of the Schubert & Salzer group of companies with 140 years of tradition and expertise in the manufacturing industry. Based in Ingolstadt, we offer Schubert & Salzer quality products “Made in Germany” through our subsidiaries in Benelux, England, France, India and the USA as well as more than 40 international partners.



Technology for tomorrow

Content

Seat valves	Page 4
Sliding gate valves	Page 10
Ball sector valves	Page 18
Segmented disc valves	Page 26
Sanitary valves	Page 30
Pinch valves	Page 32
Positioners	Page 34
Smart communication	Page 36
Electric actuators	Page 38
Customised solutions	Page 39
Service and training	Page 40

Seat valves by Schubert & Salzer

Seat valves are the extremely reliable all-rounders in the valve world. In a wide range of applications, they provide a number of benefits:

- Robust and compact
- High switching performance and wear resistance
- No water hammers when closing against the media flow
- High degree of tightness, low leakage
- Wide operating temperature range
- Simple insulation, low heat losses
- High K_{vs} value
- Easy to install and maintain

Our range includes shut-off and control valves as well as check valves and strainer in stainless steel or red brass. They are available with manual, electric or pneumatic actuators made of stainless steel, non-ferrous metal or polymer. To integrate them in pipeline systems, there is a selection of threaded fittings, welded connections, tri-clamps and flange joints.

reliable

consistent

high quality

Details



Website

Spray water protection

Position indicator

Bonnet

Piston spring

Piston

Flange

Packing

Valve stem

Disc

Seat seal

Body seat

Body

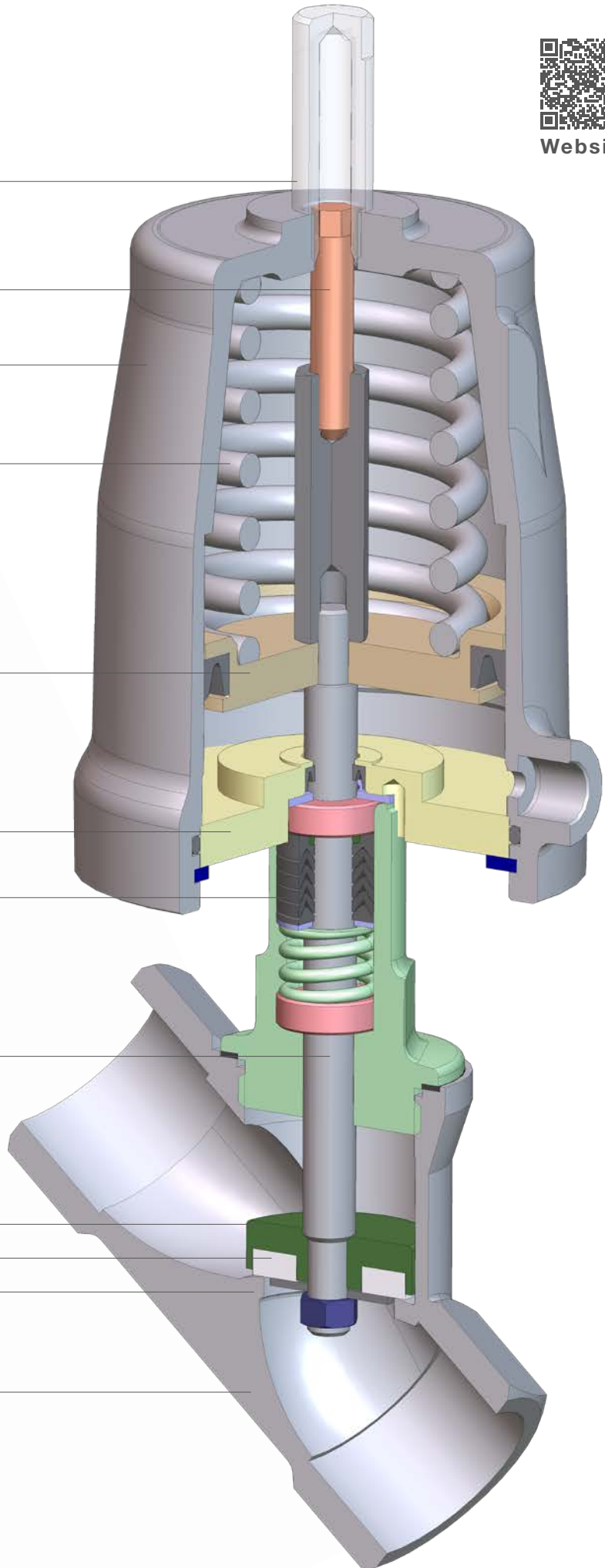

Angle seat valves

The angle seat valves from Schubert & Salzer offer a long service life, reliable on-off and precise control performance. The angled positioning of the actuators enables use in very confined spaces.

The Schubert & Salzer angle seat valves with optimised flow direction are characterised by particularly high flow coefficient (K_{vs}) values.

Angle seat valves

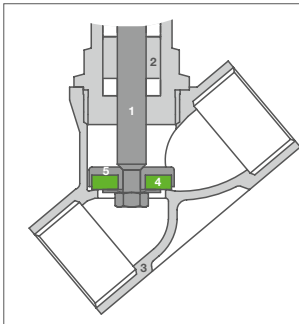

- 1 Piston rod
- 2 Packing
- 3 Body
- 4 Seat seal
- 5 Disc

Hygienic angle seat valves

With an Ra of all wetted surfaces of $< 0.8 \mu\text{m}$, the hygienic angle seat valves with their dead-space-optimised design are ideally suitable for applications in the food and beverage manufacturing sector. They are used in particular for controlling and shutting off process water, CO_2 , culinary steam and sterile air.

Hygienic angle seat valves

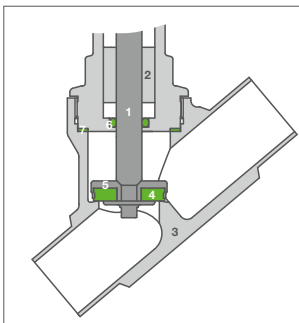

- 1 Piston rod
- 2 Packing
- 3 Body
- 4 Seat seal
- 5 Disc
- 6 Stem seal
- 7 Head section seal





Angle seat on/off valve 7010

Nominal size: DN 8 - 80
Nominal pressure: PN 16, PN 40
Media temperature: -30°C to +200°C,
optional -100°C to +220°C
Material: Bronze and stainless steel



Hygienic Angle Seat Control Valve 7025

Nominal size: DN 15 - 50
Nominal pressure: PN 40
Maximum operating pressure: 25bar
Media temperature: -30°C to +170°C,
optional -50°C to +180°C
Material: Stainless steel 1.4408,
wetted surface Ra < 0.8µm
Positioner: pneumatic, analogue
electro-pneumatic, digital electro-
pneumatic, Ex-i, FM, IO-Link



Angle seat control valve 7020

Nominal size: DN 8 - 80
Nominal pressure: PN 40
Media temperature: -30°C to +200°C,
optional -100°C to +220°C
Material: Stainless steel
Positioner: pneumatic, analogue
electro-pneumatic, digital electro-
pneumatic, Ex-i, FM, IO-Link



Angle seat manual valve 7011

Nominal size: DN 15 - 50
Nominal pressure: PN 40
Media temperature: -30°C to +200°C
Material: Stainless steel



Angle seat motor valve 7210

Nominal size: DN 8 - 80
Nominal pressure: PN 16, PN 40
Media temperature: -30°C to +200°C,
optional -100°C to +220°C
Material: Bronze and stainless steel
Actuation: on/off and control actuation,
optional position control and
position feedback plus
limit switch



Strainer 4005

Nominal size: DN 10 - 80
Nominal pressure: PN 40
Media temperature: -40°C to +220°C
Material: Stainless steel



Check valve 4000

Nominal size: DN 10 - 80
Nominal pressure: PN 40
Media temperature: -40°C to +200°C,
optional up to +220°C
Material: Stainless steel

Seat valves (1)

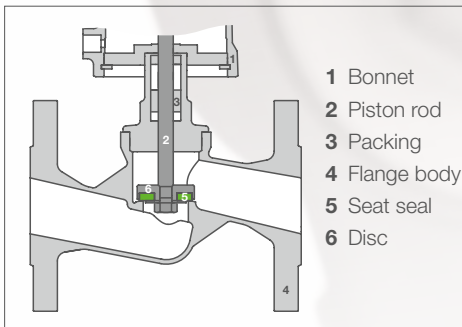

Seat valves

For globe valves, the actuator orientation is at 90° to the flow direction. The rugged design with welding ends or flanged connections is in no way less competitive than the angle seat valves in terms of performance. The traditional flange design allows the axial disassembly and reassembly of the valves.

Three-way valves (2)

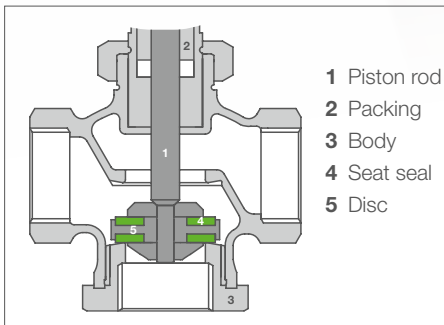

Three-way valves

Depending on its design, the three-way valve with threaded connections can perform a variety of functions: it can mix and distribute media flows or charge and discharge an operating component.

Low flow valves (3)

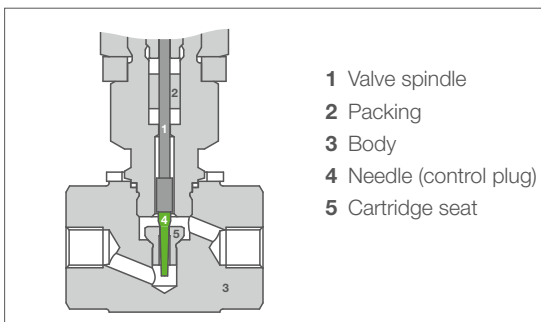

Low flow valves

Low flow valves with threaded connections and metallic seat seal are ideal for precise control or safe shut-off at high pressures and very low flow rates.

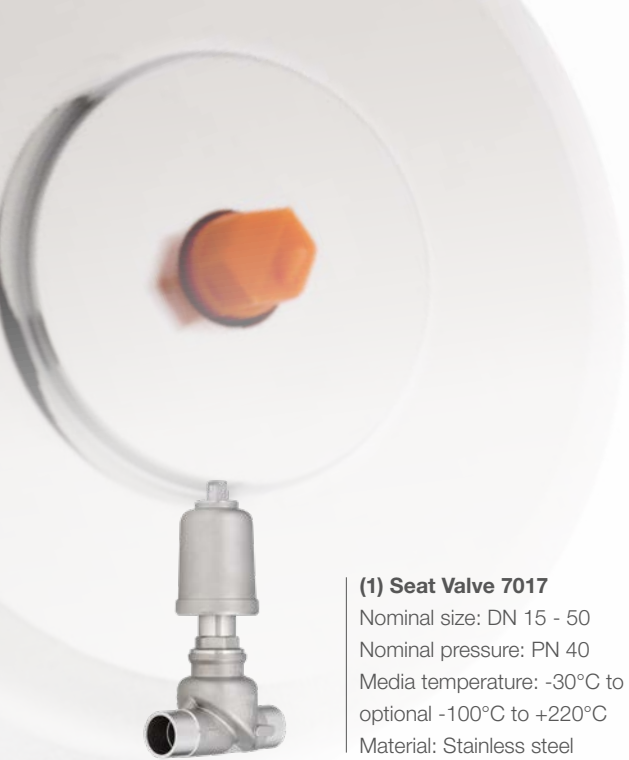

(1) Seat Valve 7017

Nominal size: DN 15 - 50
 Nominal pressure: PN 40
 Media temperature: -30°C to +200°C,
 optional -100°C to +220°C
 Material: Stainless steel



(1) Seat Control Valve 7027

Nominal size: DN 15 - 50
 Nominal pressure: PN 40,
 Media temperature: -30°C to +200°C,
 optional -100°C to +220°C
 Material: Stainless steel
 Positioner: pneumatic, analogue
 electro-pneumatic, digital electro-
 pneumatic, Ex-i, FM, IO-Link



(1) Globe valve 7032

Nominal size: DN 15 - 150
 Nominal pressure: PN 40,
 ANSI # 150
 Media temperature: -30°C to +200°C,
 optional -100°C to +220°C
 Material: Stainless steel
 Available with positioner as globe
 control valve 7037



(2) Three-way control valve 7082

Nominal size: DN 15 - 50
 Nominal pressure: PN 40
 Media temperature: -30°C to +200°C
 Material: Stainless steel
 Actuation: on/off and control actuation
 Positioner: digital electro-pneumatic,
 Ex-i, FM, IO-Link
 Available with pneumatic actuator as
 3/2-way on/off valve 7080/81 in
 stainless steel and bronze
 Combinations with motor actuators
 available



(3) Low flow valve 7042

Nominal size: DN 8 & 15
 Nominal pressure: PN 320
 Media temperature: -60°C to +210°C
 Material: Stainless steel
 Positioner: digital electro-
 pneumatic, Ex-i, FM, IO-Link
 Also available with manual
 actuator (7045) or motor
 actuator (7242 / 7342).



Right angle motor valve 7250

Nominal size: DN 15 - 50
 Nominal pressure: PN 40
 Media temperature: -30°C to +200°C
 Material: Stainless steel
 Actuation: on/off and control actua-
 tion, optional position control and
 position feedback plus limit switch
 Available with pneumatic actuator as
 on/off valve 7050 and optionally
 with positioner as right angle control
 valve 7051

Sliding gate valves by Schubert & Salzer

fast

This is how easy control can be. In the field of control valves, Schubert & Salzer has been breaking new ground for many years. We developed the sliding gate control valve: a handy, light and highly accurate valve. It operates based on a principle that had already excited Leonardo Da Vinci. Even today, it satisfies the most challenging requirements that are placed on a control valve.

The alternative when the demands are high

The sliding gate valve series controls liquid, vapour and gaseous media precisely, quickly and economically. A sealing disc (2) fixed in the body (1) at right angles to the flow direction has a certain number of crossways slots (3). A moving disc (4) with the same arrangement of slots moves parallelly to the fixed disc, thereby changing the flow cross section. The prevailing differential pressure presses the moving disc (4) against the fixed disc (2) and seals it.

Applications

Sliding gate valves are used to control and shut off gases, vapours and liquids

- Chemical and pharmaceutical industry
- Steel and aluminium plants
- Food and beverage industry
- Breweries
- Textile manufacturing
- Tyre production
- Plastics and rubber production
- Test bench technology
- Gas and compressed air production and utilisation
- etc.

innovative

accurate



Details



Positioner

Pilot line

Diaphragm shell

Diaphragm disc

Coupling

Adjusting nut

Packing tube

Conical seal

Bellows

Column

Valve stem

Body cover (1)

Coupling ring

Moving disc (4)

Fixed disc (2)

Body (1)

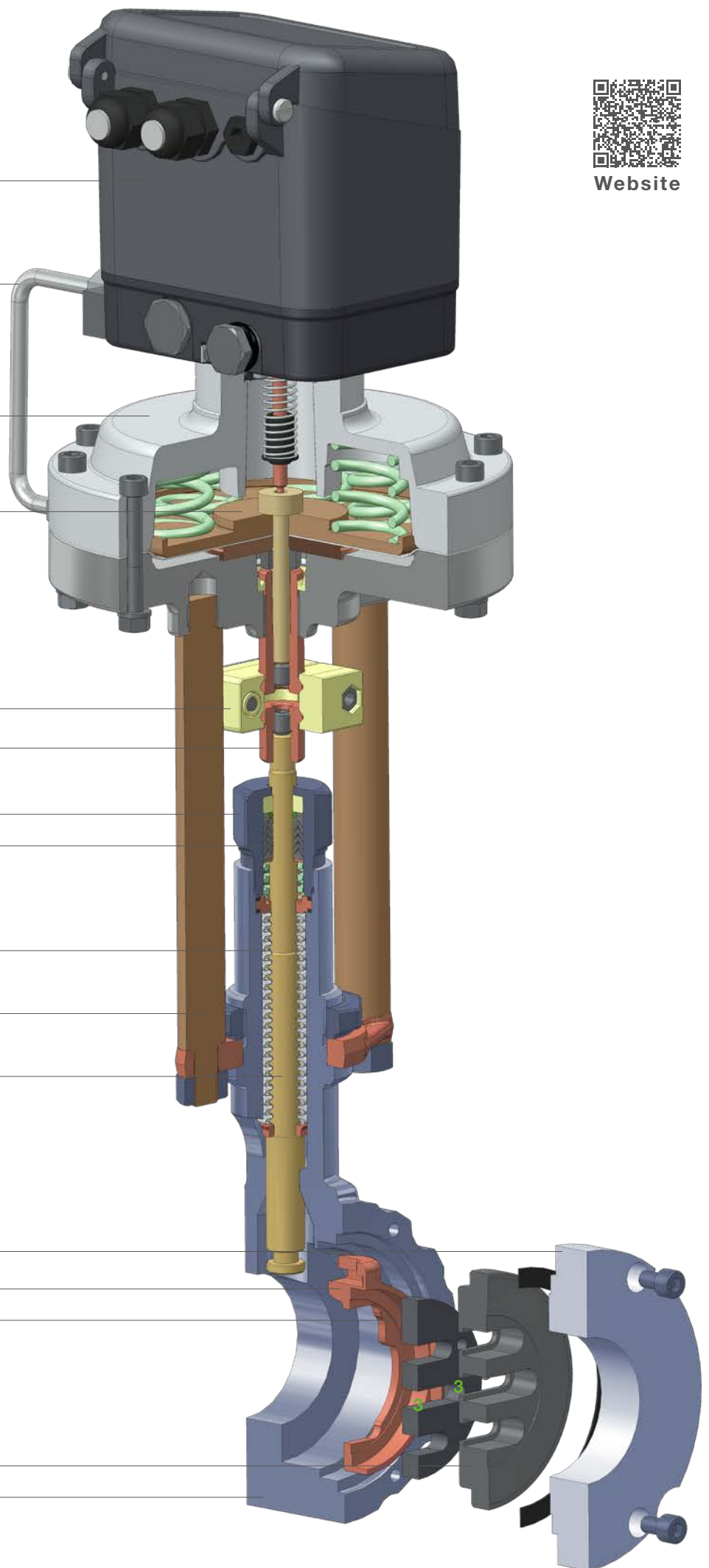

The advantages of sliding gate valves

fast

Compact design

Short installation length and extremely small actuators minimize the required space.

Easy to install and maintain

Thanks to the compact construction, the low weight (e.g. DN 150 with actuation a mere of approximately 15 kg) and the clever disc design reduces the installation and maintenance effort to a minimum.

Low leakage rate

< 0.0001% of the K_{VS} value due to the self-lapping action of the moving disc and the pressure of the medium against the moving disc, using a surface seal instead of an annular seal.

Outstanding rangeability

from 30 : 1 to 160 : 1

Variable flow coefficient (K_{VS}) values and characteristic curves

By simply replacing the fixed sealing disc, it is possible to change the flow coefficient (K_{VS}) value and the characteristic curve at any time – from K_{VS} 0.018 to 910.



Size comparison between a normal seat valve and a **Schubert & Salzer sliding gate valve**. In the example, the nominal size of both valves is identical.

Minimal wear

Related to the effect of the force which is applied at 90° to the direction of flow and minimised by the highly effective pairing of the materials used for the moving and fixed discs.

Maximum differential pressures

Control and shut-off of high differential pressures (up to 160 bar) with the smallest possible dimensions, compact length and low air consumption.

Variable flow coefficient (K_{VS}) values and characteristic curves – By simply replacing the fixed sealing disc:



100% K_{VS} value characteristic modified linear



16% reduced K_{VS} value characteristic modified linear



0,4% reduced K_{VS} value characteristic modified linear



100% K_{VS} value characteristic equal percentage



SV100 Special characteristic



Optimal flow control

Avoids cavitation problems in the valve and operates quietly by lowering turbulence.

Saves resources and climate-friendly

Sliding gate valves are more compact and weigh much less than standard seat valves. This results in conscious use being made of valuable resources and CO₂ being put to economical use in the production and during transportation. When in use, the GS valves benefit from a driving force that is reduced 10-fold. This reduces the energy consumption and is good for the climate and the environment.

precise

individual

1.4571
594320

Efficiency

The outstanding feature of the sliding gate valve is the actuating force which is about just 10% of that needed to actuate a globe valve of the same nominal size and the same differential pressure. This allows much smaller actuators with the same nominal size and almost the same flow capacity!

The decisive factor in this respect is the low actuation force required that results from the static or sliding friction of the disc pairing. Globe valves on the other hand have to overcome the force of the flowing medium.

$$\frac{F_{A, \text{ Sliding gate valve}}}{F_{A, \text{ Seat valve}}} = \frac{\Delta p \cdot \mu \cdot A_{\text{Slot}}}{\Delta p \cdot A_{\text{Seat}}} \approx 10\%$$

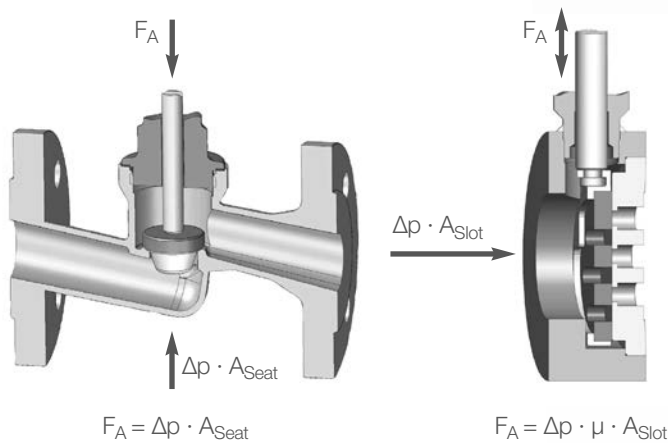

Vitality

Sliding gate control valves are considerably faster than conventional control valves. If you compare the stroke of two valves after a control signal step, it can be seen that the short stroke, the low actuating forces and the small actuator volume of the sliding gate control valves result in lower actuating times and a significantly smaller stroke amplitude in the transient condition. This high dynamism has a positive influence on the control quality of the whole control circuit.

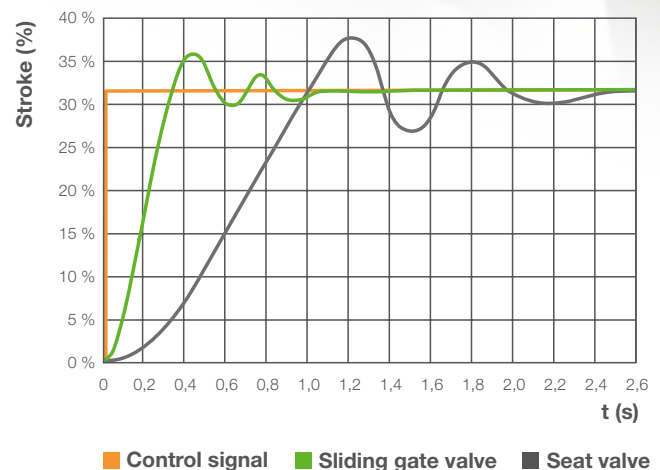

■ Control signal ■ Sliding gate valve ■ Seat valve



Cavitation

A high rate of flow through the narrowest cross section of a valve will lower the local pressure below the vapour pressure of the liquid. Vapour bubbles form which then collapse in the regions of higher pressure. When they come into contact with solid boundaries (valve body), the imploding bubbles can cause erosive damage. In the case of a sliding gate valve, these dangerous cavitation zones are external, or more accurately, they are located about **1 - 2 m** beyond the valve. The cavitation bubbles then collapse around the centre of the pipeline where they can cause no harm.

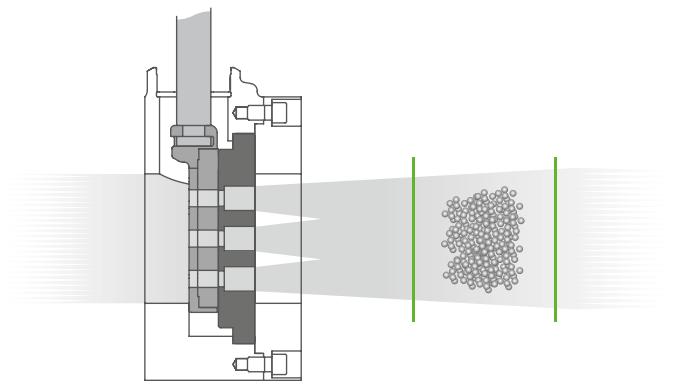

Weight

The low actuating force and short stroke allow the use of smaller actuator. Coupled with the space-saving wafer construction, weight and installation dimensions are minimised, particularly in the mid to large nominal sizes. This translates into about 150 kg for a seat globe valve in DN 150, whereas a sliding gate valve of the same nominal size weighs a mere 15 kg!

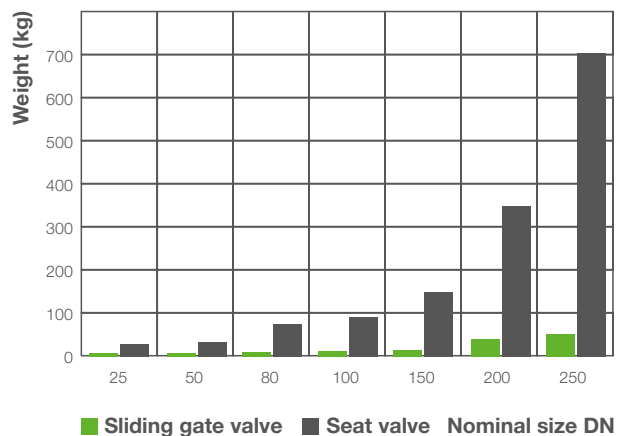

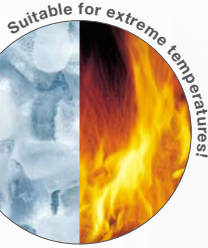

Sliding gate valve 8021

Nominal size: DN 15 - 250
 Nominal pressure: PN 10 - 160,
 ANSI # 150 - 900
 Media temperature: -60°C to +350°C,
 optional -200°C to +530°C
 Material: carbon steel, stainless steel,
 Alloy C276
 Positioner: pneumatic, analogue
 electropneumatic, digital electro-
 pneumatic, Ex-i, FM, IO-Link



Sliding gate valve 8020

Nominal size: DN 15 - 250
 Nominal pressure: PN 10 - 100,
 ANSI # 150 - 600
 Media temperature: -60°C to +350°C,
 optional to +530°C
 Material: carbon steel, stainless steel
 Available with or without positioner
 Positioner: pneumatic,
 analogue electro-pneumatic,
 digital electro-pneumatic, Ex-Version
 Special versions available!



Sliding gate valve 8028

Nominal size: DN 15 - 150
 Nominal pressure: PN 10 - 40,
 ANSI # 150 - 300
 Media temperature: -60°C to +350°C,
 Material: carbon steel, stainless steel
 Positioner: pneumatic, analogue
 electropneumatic, digital electro-
 pneumatic, Ex-i, FM, IO-Link
 Series GS1 also available as a short
 version.



Sliding gate valve 8621

Nominal size: DN 15 - 200
 Nominal pressure: ANSI # 150 - 300
 Media temperature: -60°C to +350°C
 Material: carbon steel, stainless steel
 Positioner: pneumatic, analogue
 electropneumatic, digital electro-
 pneumatic, Ex-i, FM, IO-Link
 Available with motor actuator as sliding
 gate motor valve 8638



Sliding gate valve 8043/44

Nominal size: DN 15 - 250
 Nominal pressure: PN 10 - 40,
 ANSI # 150 - 300
 Media temperature: -60°C to +350°C
 Material: carbon steel, stainless steel
 Positioner: pneumatic, analogue
 electro-pneumatic, digital electro-
 pneumatic, Ex-i, FM, IO-Link



Sliding gate valve 8040/41

Nominal size: DN 15 - 200
 Nominal pressure: PN 10 - 40,
 ANSI # 150 - 300
 Media temperature: -60°C to +350°C
 Material: carbon steel, stainless steel
 Accessories: metal bellows, pilot valve,
 limit switch, stroke limit



Sliding gate motor valve 8230

Nominal size: DN 15 - 250
 Nominal pressure: PN 10 - 40,
 ANSI # 150 - 300
 Media temperature: -60°C to +350°C,
 Material: carbon steel, stainless steel
 Actuation: On/off and control actuation,
 optional positioning control and
 position feedback plus limit switch



Sliding gate motor valve 8038

Nominal size: DN 15 - 250
 Nominal pressure: PN 10 - 100,
 ANSI # 150 - 600
 Media temperature: -60°C to +350°C
 optional -200°C to 530°C
 Material: carbon steel, stainless steel,
 Alloy C276
 Dead band: ± 0.2%
 Repeatability: ± 0.1%
 Stroking speed: adjustable between
 4,7 and 35 seconds
 Actuator: high resolution motor actuator
 for control and switching with stroke
 monitoring, limit switches and optional
 fail safe unit



Sliding gate motor valve 8037

Nominal size: DN 15 - 250
 Nominal pressure: PN 10 - 100,
 ANSI # 150 - 600
 Media temperature: -60°C to +350°C
 Material: carbon steel, stainless steel,
 Power supply: 24 ... 230 V AC/DC
 (Multi-zone power pack)
 Explosion-protected (gas version):
 II 2G Ex de [ia] IIC T6/T5
 Protection class: IP 66
 Actuation optionally also with 3-point
 control + position electronics obtainable



Sliding gate pressure regulator 8011

Nominal size: DN 15 - 150
 Nominal pressure: PN 10 - 40,
 ANSI # 150 - 300
 Media temperature: -60°C to +230°C
 optional to +300°C
 Pressure ranges: 0.3 to 10 bar
 Material: Stainless steel
 Self-acting pressure controller
 Enclosed spring housing



Sliding gate valve 8050

Nominal size: DN 15 - 250
 Nominal pressure: PN 10 - 100,
 ANSI # 150 - 600
 Media temperature: -60°C to +350°C,
 optional -200°C to +530°C
 Material: carbon steel, stainless steel



Adjustable sliding gate orifice 8090

Nominal size: DN 15 - 250
 Nominal pressure: PN 10 - 100,
 ANSI # 150 - 600
 Media temperature: -60°C to +350°C,
 optional -200°C to +530°C
 Material: carbon steel, stainless steel



robust

Ball sector valves by Schubert & Salzer

precise

The ball sector valves are used in many demanding shut-off and control applications particularly with contaminated, abrasive and pasty media.

Their construction is characterised by an extremely large rangeability and a high flow capacity. Due to the special design of the ball sector valves, the whole force of the flowing media is absorbed by the journal bearings. In this way, the pneumatic and electric actuators need for very low actuating forces.

- Minimal wear even with contaminated, abrasive and pasty media
- Precise control over a large control range
- Very high rangeability 300:1
- Extremely high K_{vs} -values
- Robust and compact design
- Long service life, low operating costs
- No flow deflection
- No draining of paper stock due to elliptical flow geometry

efficient

Details



Website

Positioner

Actuator

Control pipe

Drive adapter

Bracket

Plain bearing

Plain bearing sleeve

Packing

Plain bearing

Bearing pin

Ball sector

Seat support ring support ring

O-Ring

Seat ring

Seat retaining ring

Body

Bearing pin

Plain bearing

Packing

Plain bearing

Plain bearing sleeve

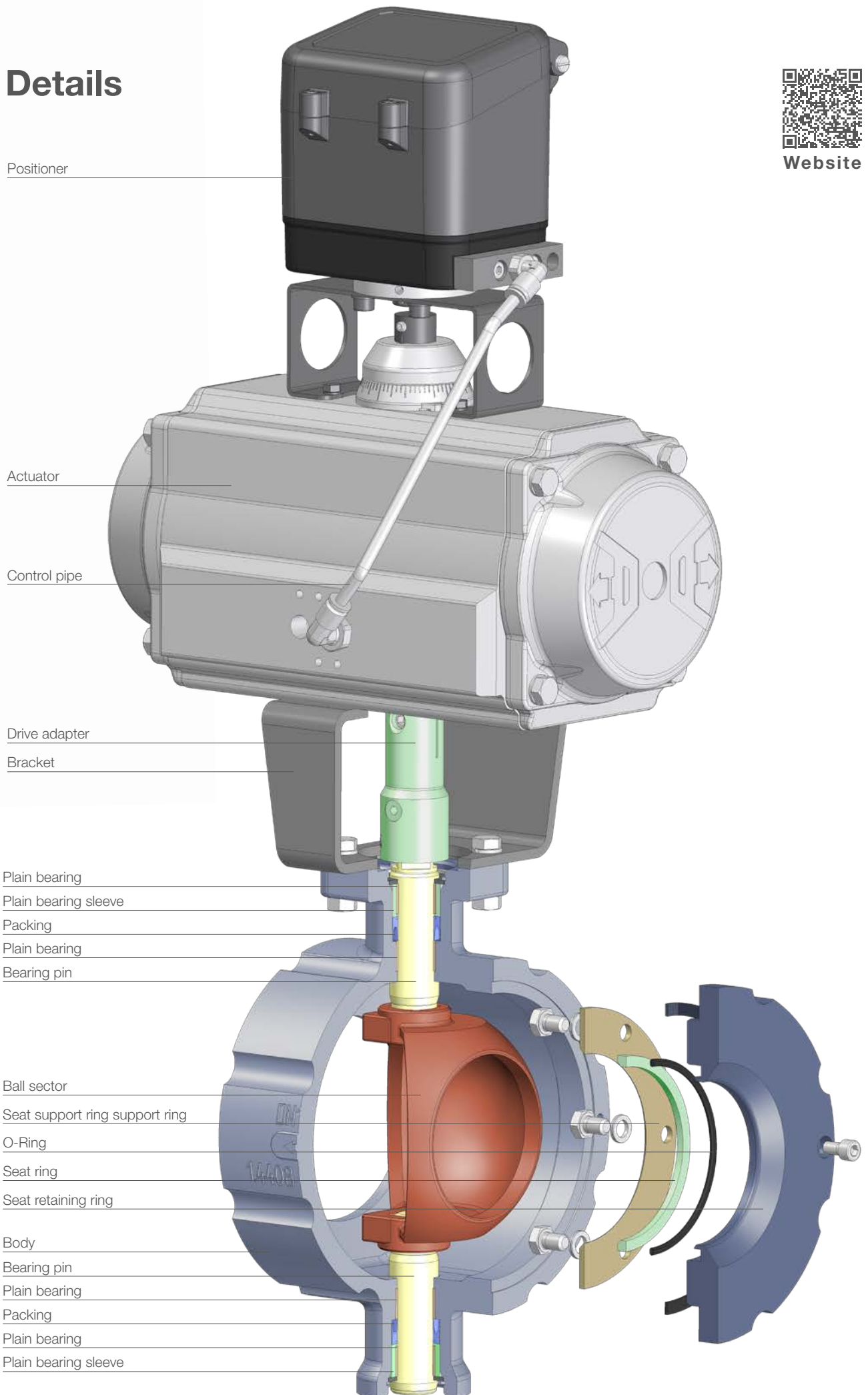

The advantages of ball sector valves

Extremely high K_{vs} values

When open, ball sector valves allow the media flow to pass through almost the entire nominal pipe diameter. They therefore achieve extremely high K_{vs} values and do not deflect the flow.

Excellent rangeability

Ball sector valves have a very high rangeability of 300:1 and therefore enable precise control over a wide control range. Combined with high-resolution actuators, the most demanding control tasks can thus be managed.

No clogging or draining with fibrous media

Ball sector valves have an elliptical flow opening, which means that even small flow rates of fibrous media (e.g. paper pulp) can be controlled without draining or clogging the valve.

Variable K_{vs} values

Because of the different flow openings of the ball sectors, the K_{vs} value can be adjusted precisely to the requirements of the respective application.



100% K_{vs} -value



63% reduced K_{vs} -value



6.3% reduced K_{vs} -value

Wear-resistant thanks to protected sealing surfaces

Due to their central bearing, the ball sectors maintain continuous contact with the seat seal during rotation. Contrary to eccentric standard rotary globe valves, the sealing surfaces of ball sector valves are therefore protected against the attack of abrasive media even in the open position.

Furthermore, solids from the medium cannot get jammed between the ball sector and the seat ring and cause damage.

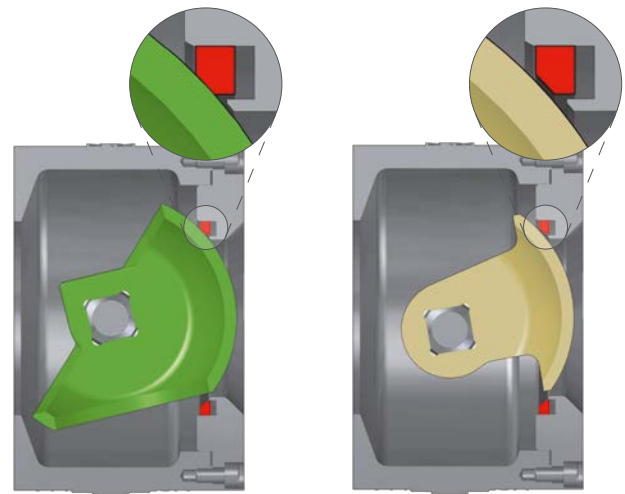

Unlike ball sector valves (left), rotary globe valves (right) lift off the seat seal when rotating. This often results in damage to the sealing surfaces of the rotary globe valves due to abrasion and jammed particles.

Durable under extreme conditions

Wear caused by abrasive media starts at the control edge of the throttle. The sealing surface on the ball sectors is far away from the control edge of the ball sector and is not exposed to high flow velocities. Even heavy wear therefore leads to leaks much less frequently and later than with rotary globe valves.

This beneficial sealing concept, combined with different materials and surface treatments for the valve seat, is the basis for long service life and reliable operation, particularly in applications with abrasive, highly viscous or fibrous media.

- Seat seal
- Available wear surface

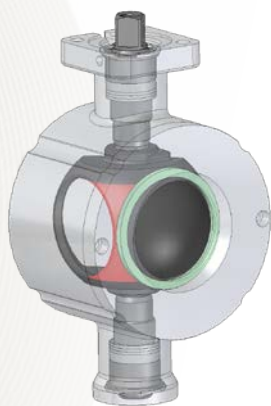

Schubert & Salzer
Ball sector valve
closed

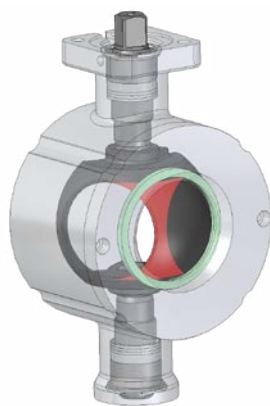

Schubert & Salzer
Ball sector valve
slightly open



Standard rotary globe
or butterfly valves
closed



Standard rotary globe
or butterfly valves
slightly open



Ball sector valve 4040

Nominal size: DN 25 - 300
 (DN 300 flanged)
 Nominal pressure: PN 10 - 40,
 ANSI # 150 - 300
 Media temperature: -40°C to +220°C
 Material: stainless steel 1.4408 (CF8M)
 and 1.4404 (316L)
 Single or double acting on/off actuators
 Positioner: pneumatic, analogue electro-
 pneumatic, digital electro-pneumatic,
 Ex-i, FM, IO-Link
 As an open/close valve, it is also availa-
 ble with an optional limit switch box and
 a manual actuator.



Ex-motorized ball sector valve 4037

Nominal size: DN 25 - 100 (others on
 request), DN 25 - 80 also available
 with spring return
 Nominal pressure: PN 10 - 40,
 ANSI # 150 - 300
 Media temperature: -40°C to +220°C
 Material: stainless steel 1.4408 (CF8M)
 and 1.4404 (316L)
 Actuator: Ex-certified motor actuator
 II2G/D EEx ia IIC T6/T5 and IEC Ex



Motorized ball sector valve 4030

Nominal size: DN 25 - 300
 (DN 300 flanged)
 Nominal pressure: PN 10 - 40,
 ANSI # 150 - 300
 Media temperature: -40°C to +220°C
 Material: stainless steel 1.4408 (CF8M)
 and 1.4404 (316L)
 With an electric actuator for controlling
 and for the open/close function incl. a
 position feedback.
 With an optional limit switch.
 Other electrical actuators available.



Highly precise ball sector valve 4032

Nominal size: DN 25 - 250
 Nominal pressure: PN 10 - 40,
 ANSI # 150 - 300
 Media temperature: -40°C to +220°C
 Material: stainless steel 1.4408 (CF8M)
 and 1.4404 (316L)
 Actuator: electric actuator, highly precise
 (1300/1600/4000/8192 steps)



Three-way ball sector valve 4080

Nominal size: DN 50 - 150
 Nominal pressure: PN 25 - 40,
 Media temperature: -40°C to +220°C
 Material: stainless steel 1.4408 (CF8M)
 and 1.4404 (316L)
 Single or double acting on/off actuators
 Positioner: pneumatic, analogue electro-
 pneumatic, digital electro-pneumatic,
 Ex-i, FM, IO-Link



**Three-way ball sector valve
 with electric actuator 4083**

Nominal size: DN 50 - 150
 Nominal pressure: PN 25 - 40,
 Media temperature: -40°C to +220°C
 Material: stainless steel 1.4408 (CF8M)
 and 1.4404 (316L)
 Incl. a position feedback.
 With an optional limit switch.
 Other electrical actuators available.

Details

Compact top mount
Schubert & Salzer
digital positioner

Wide range of
accessories available,
mounting to
NAMUR standard

Pneumatic actuator
(double or single
acting) or motor
actuator mounting to
DIN/ISO 5211

Mounting kit
according to
DIN/ISO 5211

Wafer body designed
to suit ANSI or
DIN standards
up to DN 250
(DN 300 flanged)

Centric and
maintenance-free, high
temperature bearings

Visual
position indication

Tubing

Adjustable
travel stops

Close toleranced
coupling to ensure
precise positioning
and repeatability

Ball sector optional
with hardened
surface treatments
for demanding media
and modified equal
percentage flow
characteristic with
rangeability
of 300:1

Seat retaining ring and
valve seat available in
various material
combinations; easy to
install and maintain



Three-way ball sector valves

Three-way ball sector valves combine exceptionally good K_{vs} values with superior control accuracy. They offer particularly high added value in the temperature control and mixing processes of the steel, chemical, food and beverage industries as well as in power generation, the manufacture of plastic and rubber products and for use in test benches.

Extraordinarily high K_{vs} value

Due to the sophisticated flow control and the special design of the ball sector, three-way ball sector valves achieve K_{vs} values that are around 20% higher than any of the conventional alternatives.

Excellent control behaviour

Due to the interaction of positioner, actuator and ball sector principle, a superior control accuracy is achieved with a high control spread and a rangeability of 300:1.

Versatility

The actuator can be installed at either end of the shaft, allowing for flexible integration even in complex piping scenarios.



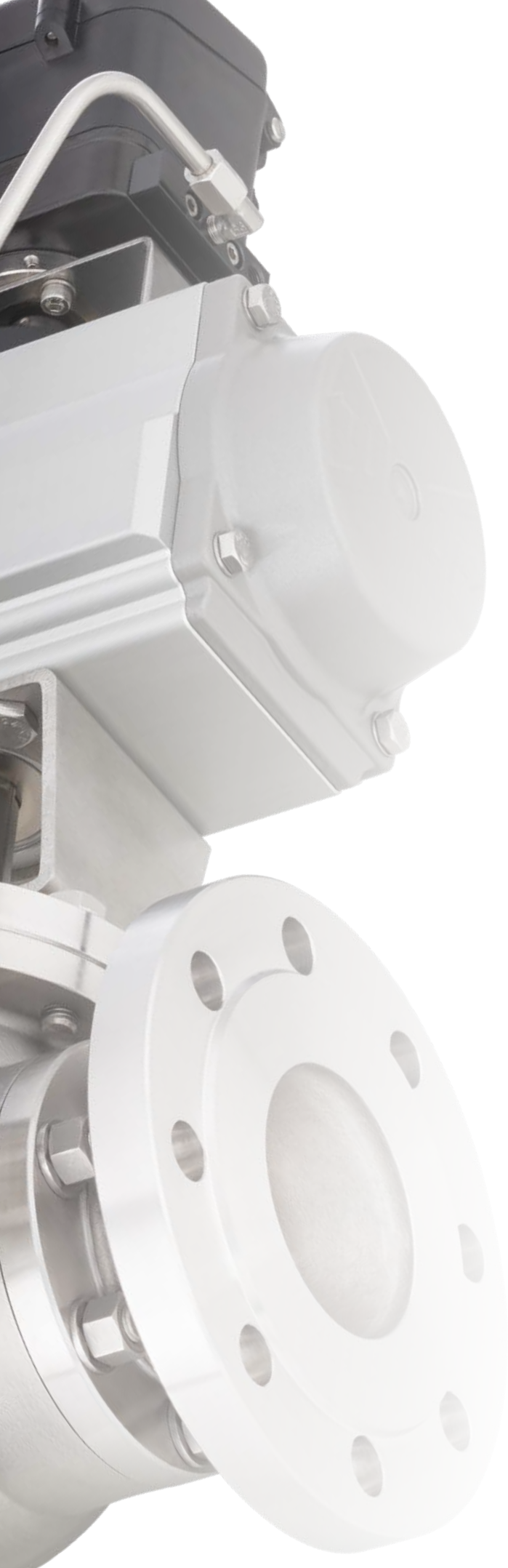

Almost constant total K_v value throughout the entire control range

Due to the special contour of the ball sector, the total K_v value of the valve remains virtually constant in any valve position when splitting or mixing.

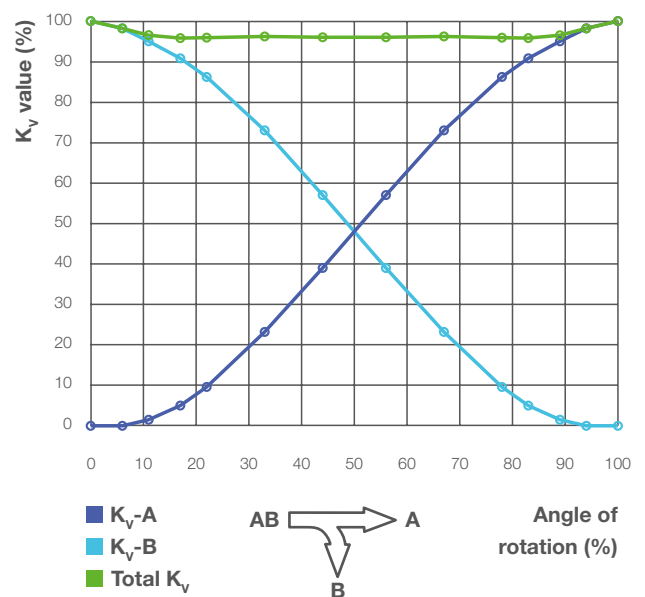
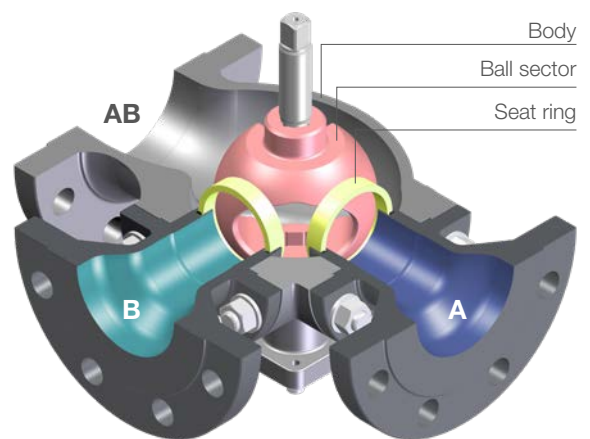

Segmented disc valves by Schubert & Salzer

Perfect and variable control with high precision over a wide flow range, this is made possible by the segmented disc valves by Schubert & Salzer.

Due to the robust design and the reciprocal flow direction, segmented disc valves are suitable for fluids as well as vapours, even if these are contaminated by particles. The wide range of applications includes areas such as building materials, chemical and power plants, pipelines, water supply and disposal, as well as shipbuilding. An ingeniously simple but effective valve design!

Functional principle

The central throttle is formed by two segmented discs that slide on top of each other and seal each other – one of them fixed, the other movable. The geometry of the fixed segmented disc determines the valve's flow capacity and characteristic. The moving disc is rotated on its fixed counterpart in such a way that the segmented flow openings continuously change.

Both discs are constantly pressed against each other by a spring assembly. This means that the flow direction is variable.

robust

durable

back sealing



The special construction of the segmented disc valves combines control accuracy even in extreme operating conditions with a high seal tightness. Even with contaminated operating media, they hardly show any signs of wear.

Details



Website

Positioner

Pilot tube

Diaphragm shell

Diaphragm plate

Coupling

Adjusting nut

Column

End positions

Protection tube

Toothed rack

Packing

Fixed segmented disc

Moving segmented disc

Sliding ring

Spring retainer

Circlip

Retaining ring

Body

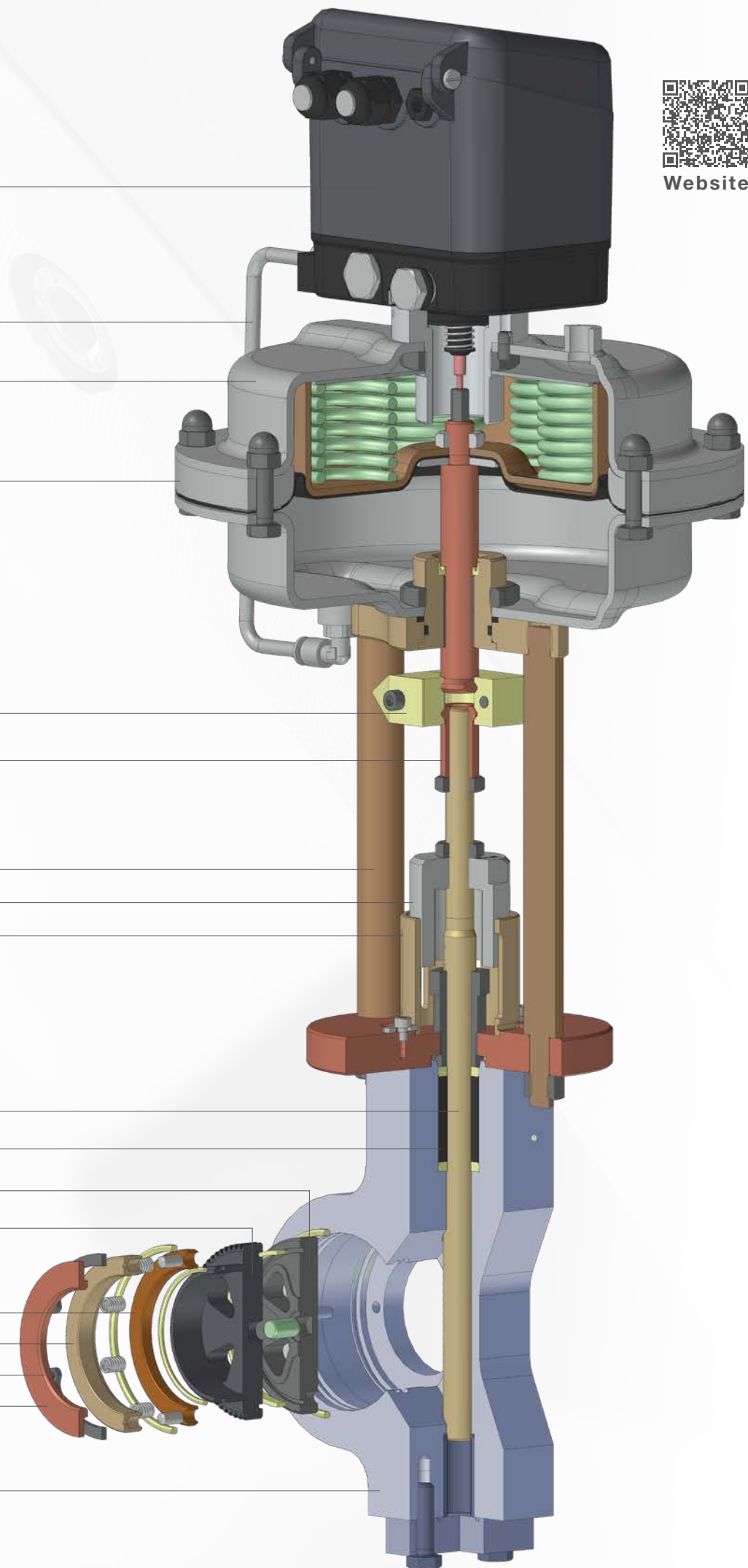



**Segmented disc valve
with pneumatic actuator 5020**

Nominal size: DN 25 - 300
 Nominal pressure: PN 25 (PN 16 for DN 250 and larger)
 Material: Stainless steel (also available in carbon steel for DN 150 and larger)
 Available with and without positioner
 Positioner: pneumatic, analogue electro-pneumatic, digital electro-pneumatic, Ex-i, FM, IO-Link



**Segmented disc valve
with motor actuator 5030**

Nominal size: DN 25 - 300
 Nominal pressure: PN 25 (PN 16 for DN 250 and larger)
 Material: Stainless steel (also available in carbon steel as for DN 150 and larger)
 Actuator: Various electrical actuators available, on/off and control actuators, optional position control and position feedback plus limit switch

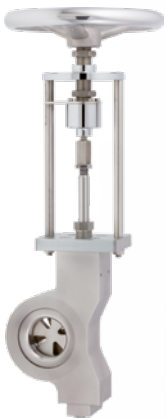

**Segmented disc valve
with manual actuator 5050**

Nominal size: DN 25 - 300
 Nominal pressure: PN 25
 Material: Stainless steel (also available in carbon steel for DN 150 and larger)
 Actuator: Smooth-running ball-bearing manual actuation

Technical Information

Design	Wafer design for flanges according to DIN EN 1092-1 type B	
Nominal sizes	DN 25 to DN 300	
Nominal pressure	DN 25 - DN 150 DN 200 DN 250 - DN 300	PN 25 according to DIN 2401 (also suitable for flanges PN 10 - PN 25) PN 25 according to DIN 2401 PN 16 according to DIN 2401
Media temperature	-60°C to +220°C (higher temperatures on request)	
Ambient temperature*	-30°C to +100°C	
Characteristic	Modified linear	
Rangeability	60 : 1	
Leakage rate % of K_{vs}	< 0.001	

* Note limits of the positioner!

Details

Analogue actuation
(such as 4-20 mA
or 3-point actuation)

Electric actuator
(customised specifica-
tions possible)

Actuators available
in various voltages
and accessories

Gear rack rotating
the moving disc

Optical position
indication

Adjustable gland
nut packing

Spring pre-tension-
ing of the sealing
disc, this means
control opposite to
the flow direction is
possible as well

Space-saving wafer
design in stainless
steel or C-steel

Hardened pairs of discs,
resistant to contaminated
media due to special profile



aseptic

Sanitary valves by Schubert & Salzer

Sanitary valves from Schubert & Salzer meet the highest cleanliness requirements along with maximum performance. Particular attention is paid to eliminating dead spaces across the entire stroke range and to avoiding residue. The components used are FDA-compliant, meet USP class VI and the directives (EC) 1935/2004 and (EU) 10/2011.

Aseptic right angle valves

The EHEDG-certified aseptic right angle valves type 6051 from Schubert & Salzer combine high control quality with the highest aseptic requirements. They guarantee ultimate rangeability. Flow analyses have been used to optimise all wetted areas with regard to maximum wall shear stresses. They meet every requirement in the pharmaceutical and cosmetics industry, but also in the biotechnology sector as well as the food and beverage technology sector.

Hygienic right angle valves

The hygienic right angle valves from the 6053 series impress with large nominal sizes and high K_{vs} values. They are characterised by excellent cleanability and ease of maintenance. In addition to beverage and food production, its range of applications includes the manufacture of cosmetics and the control of ultra-high-purity water in semiconductor manufacturing. Milk processing companies in particular benefit from the optional 3A conformity.

ultra-clean



Aseptic right angle valve 6051

Nominal size: DN 15 - 50
Nominal pressure: PN 16
Media temperature: -20°C bis +140°C
Material: Stainless steel 1.4435
Diaphragm material: EPDM with PTFE-Foil
Positioner: pneumatic, analogue electro-pneumatic, digital electro-pneumatic, Ex-i, FM, IO-Link
Available with motor actuator or pneumatic on/off actuator



Hygienic right angle valve 6053

Nominal size: DN 65 - 150
Nominal pressure: PN 16, 25
Media temperature: -25°C bis +170°C
Material: Stainless steel 1.4404
Positioner: pneumatic, analogue electro-pneumatic, digital electro-pneumatic, Ex-i, FM, IO-Link
Available with pneumatic on/off actuator

Details

precise



Website

Positioner

Sensing pin

Bolt

Spring for piston

Pilot line

Piston

Flange

Bonnet

Valve stem

Tri-Clamp

Diaphragm

Body

Control cone

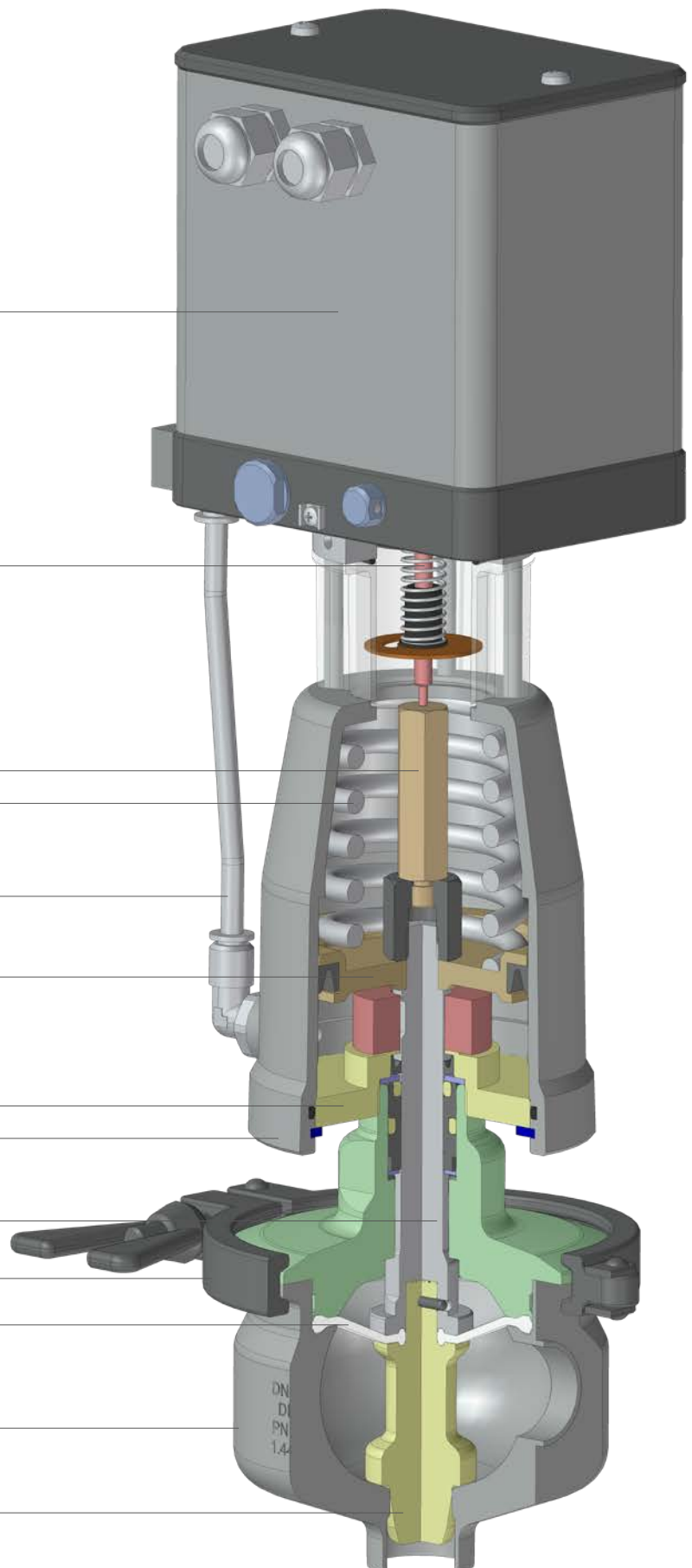

versatile

Pinch valves by Schubert & Salzer

On Schubert & Salzer pinch valves, only the tube itself, or a few components, come into contact with the operating medium. They are suitable for safely shutting off and controlling in a wide variety of processes and applications.

Endless tube pinch valves have absolutely no dead spaces and therefore provide a modern solution for applications with the highest hygienic requirements e.g. in the pharmaceutical industry, cosmetics and biotechnology.

Pinch valves with an enclosed metal housing are used for lower hygienic requirements such as in food and beverage applications, environmental technology and water treatment, as well as in electroplating. Their straight valve passage is particularly advantageous for contaminated, abrasive and viscous media.



Website

straight

resilient



Pinch valves

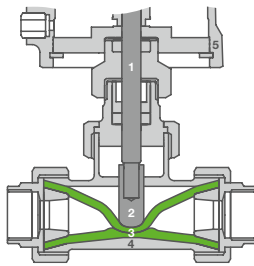

- 1 Piston rod
- 2 Actuating pin
- 3 Tube
- 4 Body
- 5 Bonnet

Endless tube pinch valves

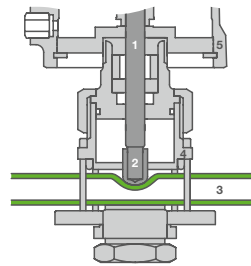

- 1 Body
- 2 Actuating pin
- 3 Tube
- 4 Body
- 5 Bonnet

Mini pinch valve 7071

Nominal size: DN 2 - 6
 Tube external diameter: 4 - 9 mm
 Operating pressure: to 2 bar
 (depending on tube)
 Media temperature: -30°C to +100°C
 (depending on tube)
 Material: Polyamide



Pinch shut off valve 7078

Nominal size: DN 15 - 50
 Operating pressure: to 6 bar
 Media temperature: -40°C to +160°C
 (depending on tube)
 Tube material: NBR and
 EPDM (conforming to FDA),
 FKM, and more



Endless tube shut off valve 7072

Nominal size: DN 6 - 14
 Tube external diameter: 10 - 18 mm
 Operating pressure: to 4 bar
 (depending on tube)
 Media temperature: -30°C to +170°C
 (depending on tube)
 Material: Stainless steel



Pinch control valve 7079

Nominal size: DN 15 - 50
 Operating pressure: to 6 bar
 Media temperature: -40°C to +160°C
 (depending on tube)
 Tube material: NBR and
 EPDM (conforming to FDA),
 FKM, and more
 Positioner: pneumatic, analogue
 electro-pneumatic, digital electro-
 pneumatic, Ex-i, FM, IO-Link



Endless tube control valve 7077

Nominal size: DN 6 - 14
 Tube external diameter: 10 - 18 mm
 Operating pressure: to 4 bar
 (depending on tube)
 Media temperature: -30°C to +170°C
 (depending on tube)
 Material: Stainless steel
 Positioner: pneumatic, analogue
 electro-pneumatic, digital electro-
 pneumatic, Ex-i, FM, IO-Link



Positioners by Schubert & Salzer

Compact positioners in analogue and digital versions mounted on pneumatic control valves.

- High precision and minimum hysteresis**
 Because the positioner is integrated in the valve actuator, no moving parts (return stroke) are accessible from the outside. The operational safety and particularly the control accuracy are thus significantly increased.
- Low compressed air consumption**
 Through the use of piezo and solenoid valves, the consumption of compressed air is minimized significantly compared to standard positioners.
- Self-adaptation and diagnostics**
 Configuration and diagnostics function by means of "DeviceConfig" software.



DeviceConfig by Schubert & Salzer

Maximum efficiency and performance – with the configuration and diagnosis software, "Device-Config", you have control over all of the digital positioners and motor actuators from Schubert & Salzer.



- Calibration and optimisation of the positioners and motors to the used valve with just a few clicks.
- Numerous diagnosis functions provide for a fast and simple fault analysis.
- Configuration of individual maintenance settings.
- Connections is possible via Bluetooth or USB using a connector
- At least compatible with the following types: 8049, 2040, 2030, 2032.



Digital Positioner 8049

Connections: G 1/8", NPT 1/8"
 Input signal: 0/4 - 20 mA,
 optional 0/2 - 10 V
 Adaptation to actuator: self-learning
 Adaptability: 3 - 28 mm (sliding stem),
 optional to 50mm (sliding stem),
 max. 270° (rotary stem)
 Versions: 2- and 4-wire
 Ambient temperature: -10°C to +75°C
 Also in Ex-i & FM version
 Optional feedback module available



Digital Positioner 8049 (stainless steel)

Entirely in stainless steel
 Connections: G 1/8", NPT 1/8"
 Input signal: 0/4 - 20 mA,
 optional 0/2 - 10 V
 Adaptation to actuator: self-learning
 Stroke range: 3 - 28 mm
 Versions: 2- and 4-wire
 Ambient temperature: -10°C to +75°C
 Also in Ex-i version



Digital Positioner 8049 IPC

Positioner with integrated
 process controller
 Input signal: 0/4 - 20 mA, PT-100
 Sampling rate: ca. 50 ms
 Set point setting: external/internal
 Ambient temperature:
 -10°C to +75°C



Positioner 8047 i/p + p/p

Input signal range:
 electro-pneumatic 0/4 - 20 mA
 pneumatic 0.2 - 1 bar
 Stroke range: 5 - 22 mm
 (depending on stroke return spring)
 Pilot energy: 3 - 6 bar
 Hysteresis: < ± 1%
 Air consumption: 400 - 600 NI/h
 (depending on air supply)
 Also in Ex-i version



Control head 2041

Position indicator for linear actuators
 with an integrated pilot valve
 Nominal stroke: 2 - 30mm
 Protection class: IP67
 Supply: 24 V DC, ASi, IO-Link
 each incl. solenoid valve
 Electrical connection: M12 connector
 Ambient temperature:
 -20 °C to +60 °C

efficient

Smart communication by Schubert & Salzer

As the digitalisation of industry progresses, the focus is shifting to smart devices that not only reliably fulfil their function, but also actively communicate information about their status.

With smart communication systems such as IO-Link or IIoT (Industrial Internet of Things), modern control valves with positioners type 8049 can now provide extensive status data, which – in addition to enabling predictive maintenance planning – can also make error analysis and commissioning much easier, for example.

What is IO-link?

IO-Link is a standardised communication system that enables the bidirectional exchange of data between sensors, actuators and control systems. Standardised cables with M12 connectors and so-called IO-Link masters form the infrastructure between the higher-level control system and devices at field level, such as the control valves with positioner type 8049 from Schubert & Salzer.

What is the Industrial Internet of Things (IIoT)?

The concept of the Industrial Internet of Things (IIoT) describes the networking of devices and systems in industry in order to collect, analyse and evaluate data. Thanks to special IIoT modules, Schubert & Salzer positioners make their status data available to the user's cloud.

Predictive Maintenance

Monitoring and evaluation of the centrally (IO-Link) or globally (IIoT) available status data facilitate the predictive planning of maintenance measures.

Fast, targeted troubleshooting

Physical access to the valve is not necessary to detect anomalies and deviations in the control behaviour. The IIoT platform can also be used to enable online access for service technicians to find a solution within a very short time and without an on-site visit.

Simple commissioning and replacement with IO-Link

A single cable with an M12 plug bundles the positioning signal, position feedback, data transmission and power supply. Wiring errors are technically impossible due to the coded connecting plugs.

When replaced, the new positioner type 8049 automatically adopts the previously used parametrisation and is immediately ready for operation after a self-calibration.

digital

easy-to-use

Global data availability with IIoT

Status data stored in the system operator's cloud is available worldwide for evaluation and analysis.

Cybersecurity as a design principle

The IIoT module is controlled by the positioner and only sends data to the cloud that the positioner actively provides. The module is technically unable to request data itself, actively execute commands or make changes to the positioner.



Electric actuators

Besides a precise throttling element, a precise actuator is also required for solving complex control tasks.

This requirement is met in full by the two electrical Schubert & Salzer actuators type 2030 and type 2032. The development particularly focused on control accuracy, high positioning speed and reliability. As with all electronic components by Schubert & Salzer, communication and settings of all parameters are handled via the configuration software DeviceConfig.



Actuator 2030

Fast and high-resolution actuator
Regulating speed up to 0.75 s/mm
Dead band: $\pm 0.2\%$ of the valve stroke
Repeatability: approx. $\pm 0.1\%$
Actuating force: 2.0 kN and 5.0 kN
Protection class: IP67
Ambient temperature: -10°C to $+60^{\circ}\text{C}$
Low temperature version up to -40°C
Automatic valve adaption
Diagnostics functions
Also available with safety position in case of power failure



Actuator 2032

Compact and precise actuator
Regulating speed up to 1.5 s/mm
Dead band: $\pm 0.6\%$ of the valve stroke
Repeatability: approx. $\pm 0.3\%$
Actuating force: 0.8 kN
Protection class: IP65
Ambient temperature: -10°C to $+60^{\circ}\text{C}$
Automatic valve adaption
Diagnostics functions
Also available with safety position in case of power failure

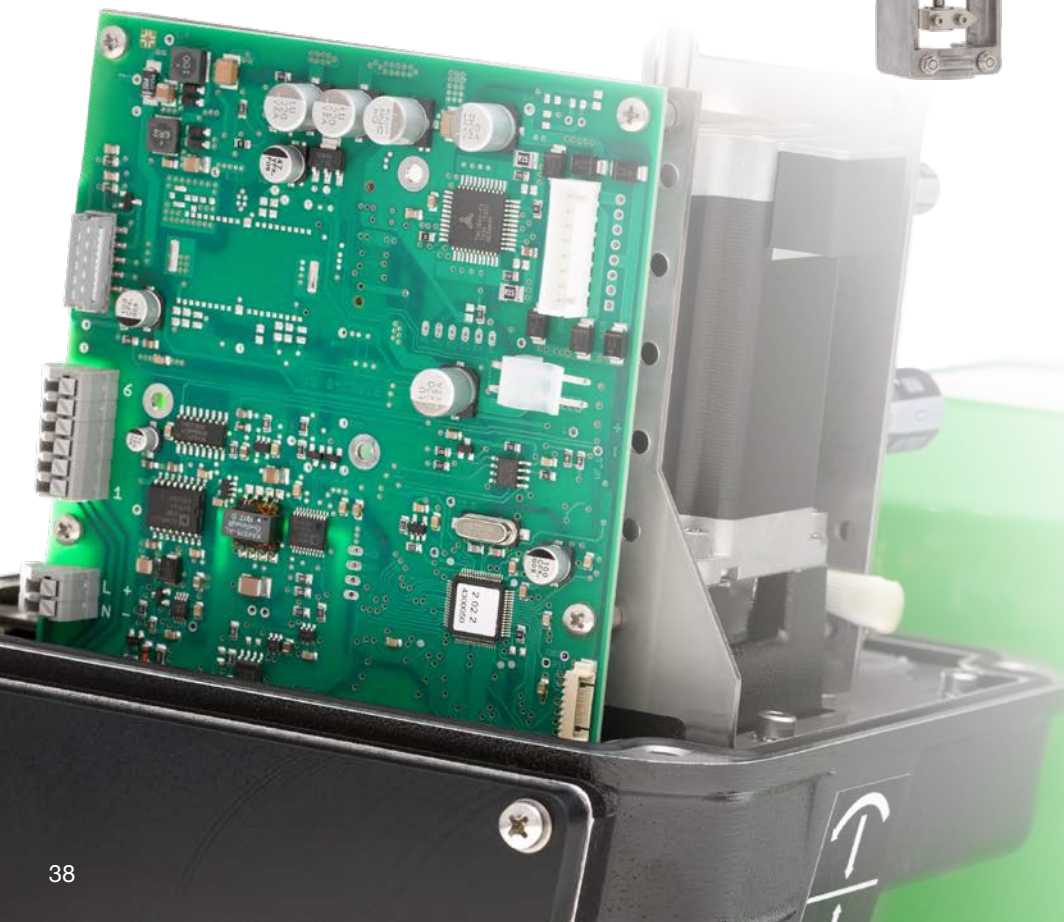

Customised solutions

Compact valve manifolds

Less piping effort, reduced maintenance time and minimized investment costs.

In many systems, processes demand connecting multiple valves for different media so that they can together carry out a special process function. A connection system well-known from the field of hydraulics and adapted to the respective application, allows for the intelligent combination of several valves in a customer-specific manifold. All necessary connections between the individual process valves are integrated in the manifold. On the customer side, connections for hydraulic fluid input and output in the desired number are



available depending on the requirement. Manifolds can be manufactured either completely from stainless steel or solid carbon steel with screwed valve seats. Additional pressure and temperature sensors can be integrated at any time. The manifolds are developed and manufactured individually according to your P&I diagrams.

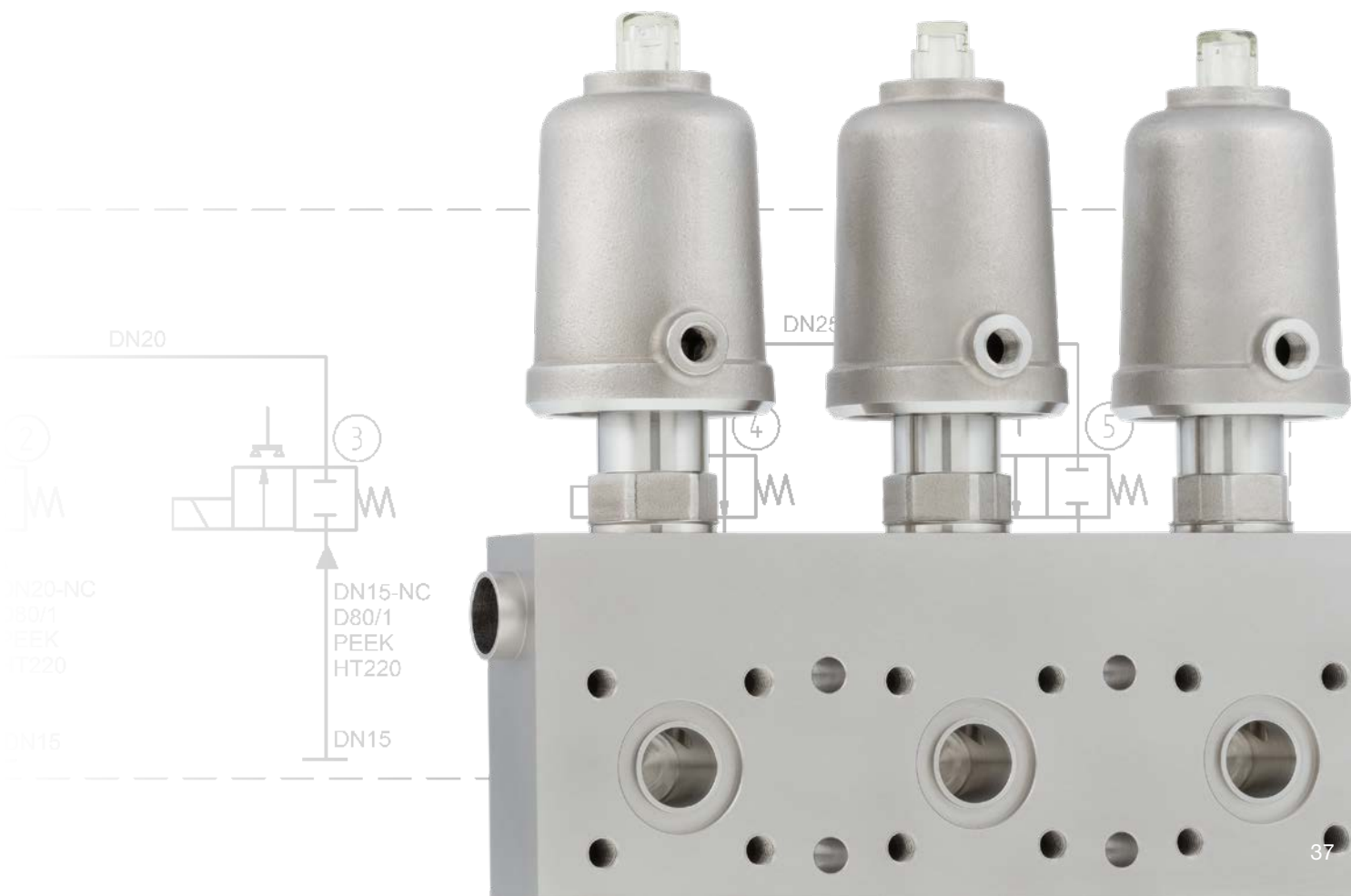

Service and training by Schubert & Salzer

The process and operating safety of our customers is our ultimate priority. That is why we are quick to offer you support and advice at all times even after the delivery of our products.

Commissioning of equipment

Commissioning a new piece of equipment is a challenge in itself. We help you do this! Our professional service staff complement your team and correctly integrate our products with your process. They ensure that everything “runs smoothly” – right from the beginning.

Repair and maintenance

We support you by maintaining our products on site or carry this out for you completely at our premises. Keeping stock of common spare parts enables us to react quickly and carry out the work at short notice.

Available training

Our multifunctional training centre in Ingolstadt offer the perfect environment for training individual employees or entire teams from the maintenance and engineering departments. A modern water and steam test station that meets the latest state of the art is available for this purpose.

In talks with our experts, you will gain valuable practical knowledge surrounding maintenance and repair measures for our products. You will be given tips about the individual configuration and optimisation of the valves for your applications. We are also happy to conduct training sessions at your site.





Added value from training:

Valves from Schubert & Salzer are particularly easy to maintain and service. With a few simple steps, it is possible, for example, to replace the positioner, main wear parts or the actuator.

The diagnostic data extracted from positioners and electrical actuators can be evaluated after a short tutorial in order to derive optimization measures for your application.

